



Granulator Model BM-309

MODEL BM-309

- Rotor : Machined, robust and very efficient rotor
Three (3) staggered section wheels. Each wheel have three (3) rotary knives, fabricate with high impact steel and wear resistant.
- Rotary knives (Qty : 9) : Made with high impact steel (1 cutting edge)
- Anvil knives (Qty : 2) : Made with high impact steel (1 cutting edge)
- Drive : 2 inertia wheels (one wheel is machined for a pulley 5V)
- Safety limit switch prevent operation when servicing
- Motor 30 H.P. High Frequency 575 volts 3 ph
- Starter : 30 H.P.
- **Application : Plastic, film, rubber, metal, wood, ACSR cable**
- Rotor diameter : 20.56", circumference square inch : 678
- One abrasion resistant steel screen with a choice of hole size
- Horizontal input height for cable, tube, etc. : 39"
- Input dimensions : 9" width x 5 1/2" height
- Vertical input height for small parts : 70"
- Input dimensions : 14" x 11 1/2"
- Motor/transmission for the feed 3/4 H.P. with amps control
- Starter 3/4 H.P.
- Output of granulated products :
 - Belt conveyor can be installed
 - Aspirator/cyclone can be installed
- Grinding capacity : 1,000 to 2,000 pounds/hr depend the output size material
- Dimensions :

Height	81"
Width	36"
Length	70"
- Color : Green
- Weight : 2,700 lbs

ADVANTAGES

- Safe
- Easy to operate, Reliable
- Need little maintenance

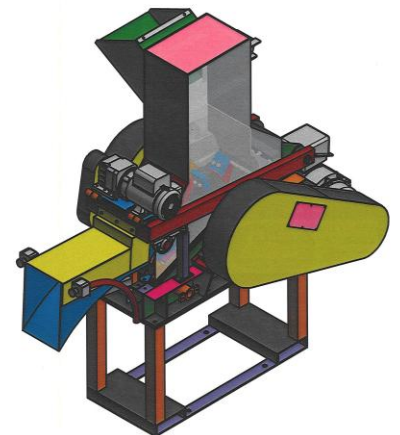
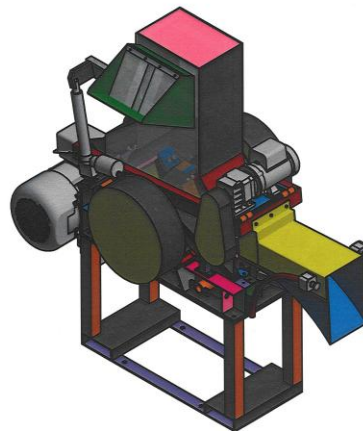

**Entry speed : 30 ft/min.
with amps control**

An entry : driver feed roller for guide all products, example : rubber, metal wires, electric cables, plastic pipe and other pieces in continuity, directing to the knives.

Manufactured & sold by :

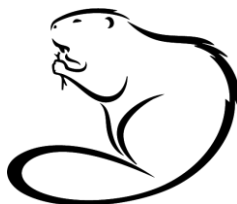

Beaver Products

6670, Rte 120 Lac Baker, N.-B. E7A 1N2
Tél. : 506-992-2356 Fax : 506-992-3926
pelletier@nb.aibn.com



Made in Canada
Fabriqué au Canada